

Computer Room Floorstands

Effective Date: 7/1/08

Bulletin Number:801070-1

Features:

- Customized cover plates align with anchor bolt locations and bottom cable entry of supported equipment. This matched design allows cable access while restricting escaping air conditioning.
- Optional side panels with conduit knockouts further restrict escaping air.
- Stands can be bolted together in series.
- Leveling feet designed to allow rotation and anchoring to the floor.
- Custom designed for any height of raised floor.
- Seismic analysis available.

*Every floorstand is custom,
contact
IntraPack for your specific needs.*

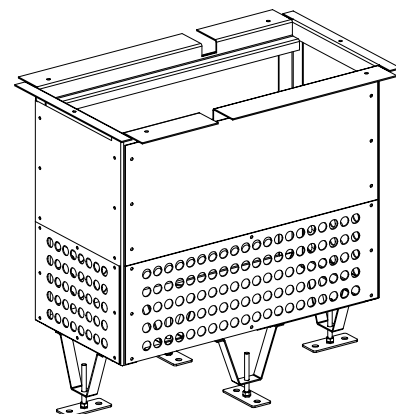
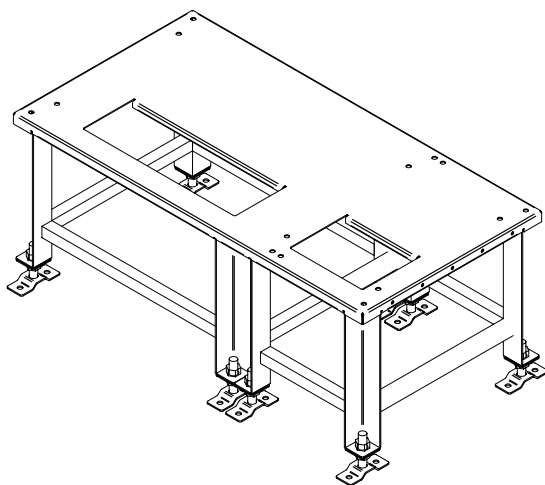
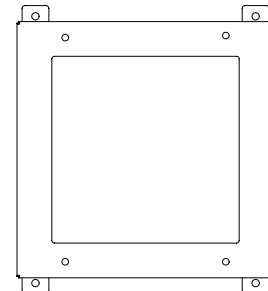
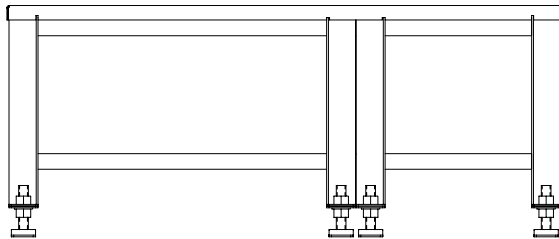
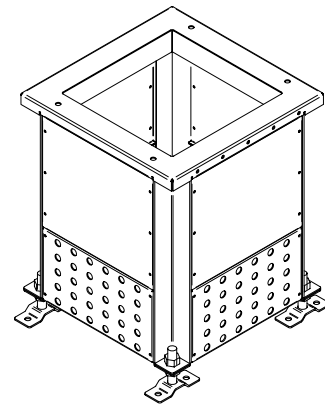

Examples of typical floorstands.